

# KEMCO SYSTEMS

## Wastewater Heat Recovery

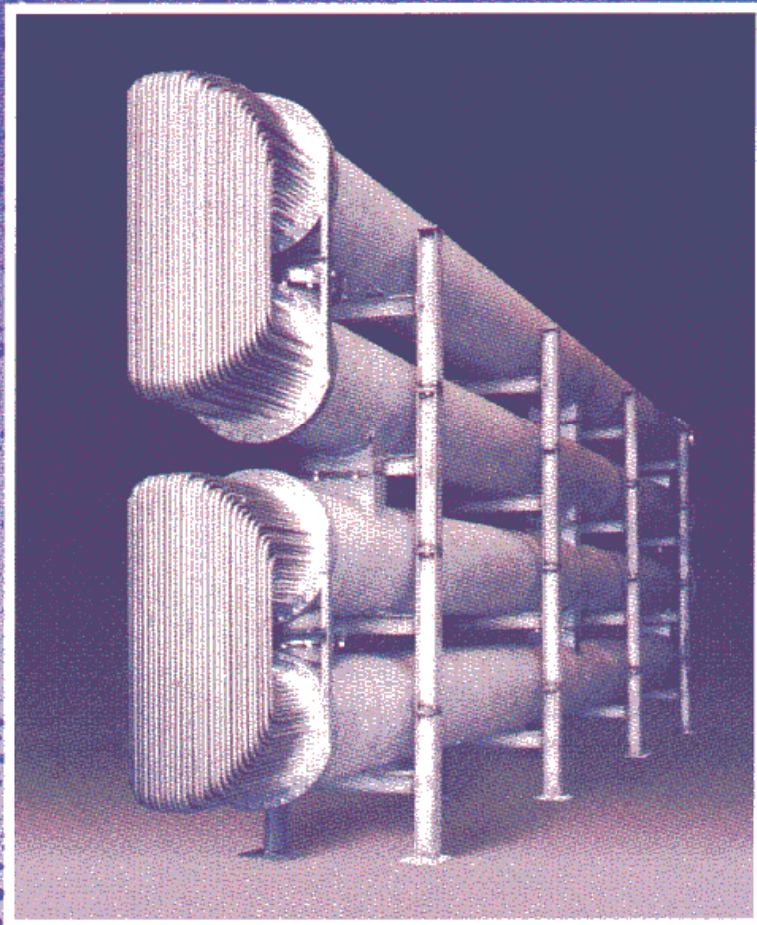

SINCE

1969



R & B WHITEMAN (Sales) Pty Ltd ■ PO Box 1214, Hawksburn ■ VIC 3142 AUSTRALIA  
P: 61 3 9525 0222 ■ F: 61 3 9525 0244 ■ [info@rbwhiteman.com.au](mailto:info@rbwhiteman.com.au) ■ [www.rbwhiteman.com.au](http://www.rbwhiteman.com.au)

# SAVE ENERGY

## KEMCO's Wastewater Heat Recovery System

### EFFICIENT

KEMCO's Wastewater Heat Recovery System recovers potentially lost thermal energy by capturing the heat from the wastewater and using it to preheat the incoming fresh water. These systems are extremely efficient and can be designed to provide up to a 5° F "approach".

For example, if the temperature of incoming fresh water is around 60°F to 65°F, a KEMCO Heat Recovery System can effectively preheat that water to within 5°F to 10°F of the wastewater stream. That could be up to 60% of the

original energy expended. And you can expect a return on initial investment from 12 to 24 months.

### COMPACT

KEMCO's shell and tube heat reclaimers are designed to be wall or ceiling mounted, so they do not use valuable production floor space.

### FLEXIBLE

Kemco heat reclaimers can be designed to provide more than one preheated temperature - perfect for hot and tempered water systems.

### DURABLE CONSTRUCTION

Stainless steel construction assures optimum corrosion resistance and longer operational life. KEMCO Wastewater Heat Recovery Systems meet or exceed TEMA standards for shell and tube heat exchangers.

### SELF CLEANING

KEMCO's 4-Way Back Flushing System not only guarantees against plugging, but eliminates any need for manual cleaning of the exchanger. They don't have to be taken apart and cleaned, which is often the case with other types of heat exchangers. That's one more reason why KEMCO's Wastewater Heat Recovery Systems come with a 20-year warranty.

### SUPERIOR PERFORMANCE

KEMCO's heat reclaimers do not require the wastewater to be filtered prior to entering the unit, which is required for plate and frame units. This eliminates additional electrical consumption required by filtration systems and provides hotter wastewater to the reclaimer.

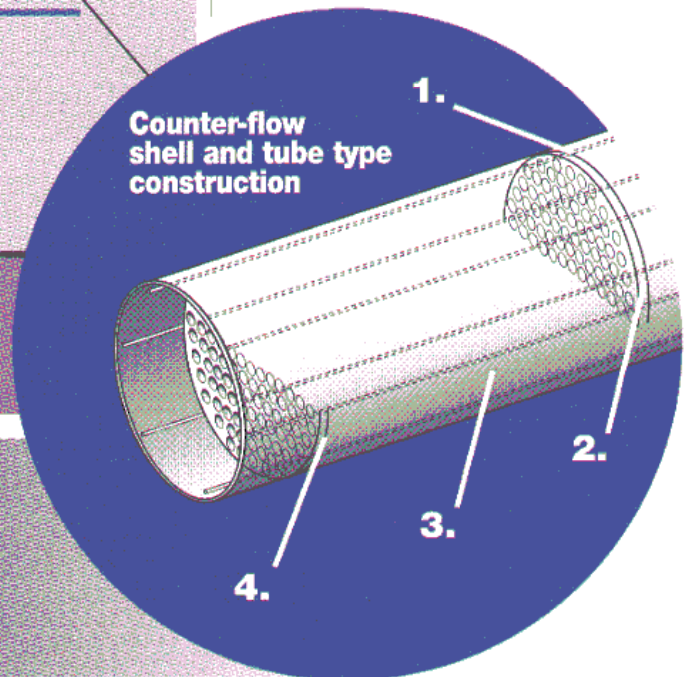
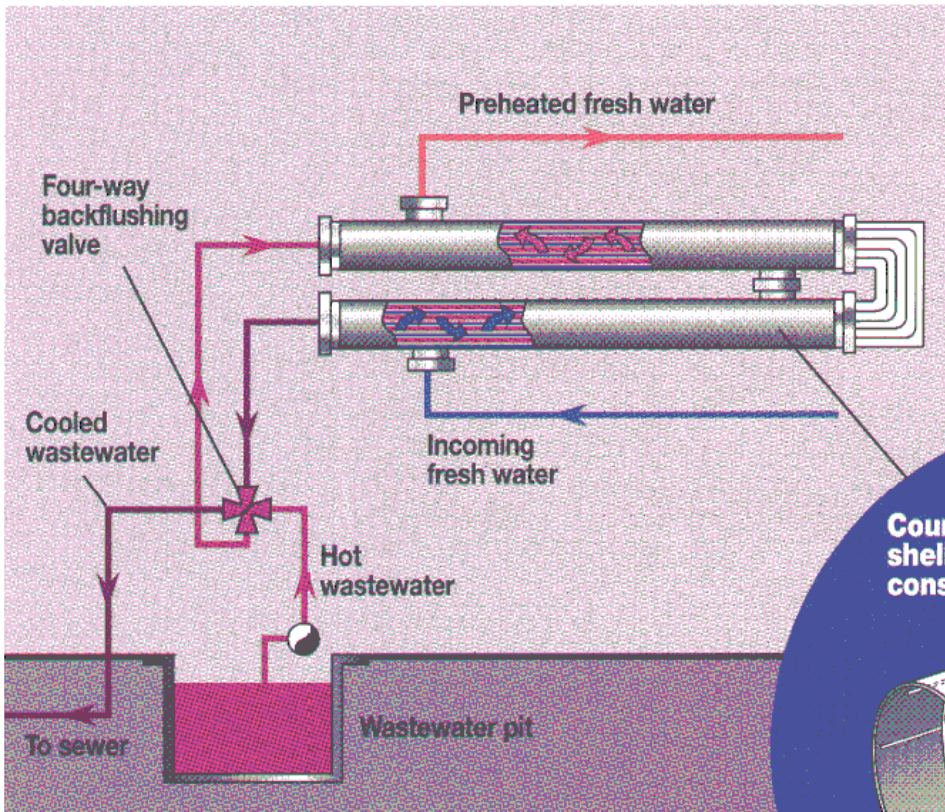

1. Precision tolerances between baffles and the shell reduce heat loss due to leakage and increase thermal efficiency overall.

2. Weldless assembly of baffles eliminates tube damage due to baffle shift from thermal expansion.

3. Baffles and spacing rods are installed closer for maximum tube support and vibration control.

4. KEMCO's baffle window design assures greater heat transfer per square foot.



FROM METER TO SEWER: TOTAL INDUSTRIAL WATER SYSTEM SOLUTIONS SINCE 1969



R & B WHITEMAN (Sales) Pty Ltd ■ PO Box 1214, Hawksburn ■ VIC 3142 AUSTRALIA

P: 61 3 9525 0222 ■ F: 61 3 9525 0244 ■ info@rbwhiteman.com.au ■ www.rbwhiteman.com.au